

Service Schematics

NOKIA 6085

Introduction

IMPORTANT:

This document is intended for use by authorized NOKIA service centers only.

“Service Schematics” was created with focus on customer care.
The purpose of this document is to provide further technical repair information for NOKIA mobile phones on Level 3/4 service activities.
It contains additional information such as e.g. “Component finder”.
The “Signal overview” page gives a good and fast overview about the most important signals and voltages on board.
Saving process time and improving the repair quality is the aim of this document.
It is to be used additionally to the service manual and other training or service information such as Service Bulletins.

All measurements were made using following equipment:

Nokia repair SW : Phoenix version 2006.34.2.156
Oscilloscope : Fluke PM 3380A/B
Spectrum Analyzer : Advantest R3162 with an analog probe
RF-Generator / GSM Tester : Rhode & Schwarz CMU 200
Multimeter : Fluke 73 Series II

While every endeavour has been made to ensure the accuracy of this document, some errors may exist. If the reader finds any errors, NOKIA shall be notified in writing.

Please send E-Mail to: training.sace@nokia.com

RM-198



A NEW FEATURE FOR ON-LINE USE

We have now linked those measurement points ① which are related to the oscillograms shown on the signal overview page. As example: clicking on the measurement point ① guides you to the matching oscillogram on the signal overview page. The next click onto the now shown signal guides you to the related measurement point on the module. Finally, a third click, now onto the measurement point ① on the module, takes you back to the starting point inside the schematics.

Do you have further improvement ideas or would like to give us feedback?
Please send an email to: training.sace@nokia.com

Table of Content

Front page	1
System connector	2
Retu, Tahvo, LED driver	3
RAPGSM, Memories, FM radio, BT	4
User interface	5
Flip PWB	6
RF part	7
Signal overview	8
Component finder	9

Copyright © NOKIA

This material, including documentation and any related computer programs is protected by copyright, controlled by NOKIA. All rights are reserved. Copying, including reproducing, modifying, storing, adapting or translating any or all of this material requires the prior written consent of NOKIA. This material also contains company confidential information, which may not be disclosed to others without the prior written consent of NOKIA.

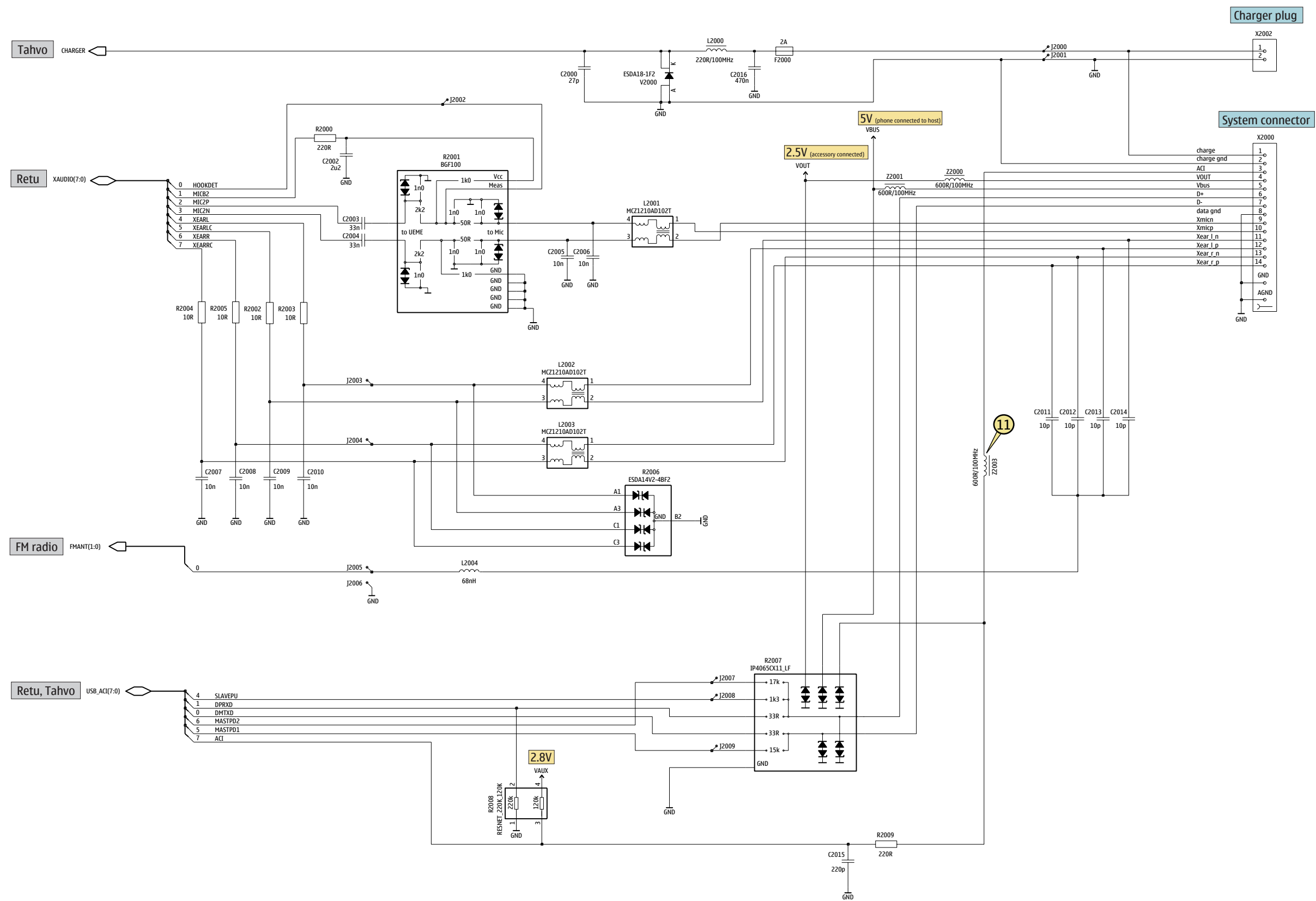

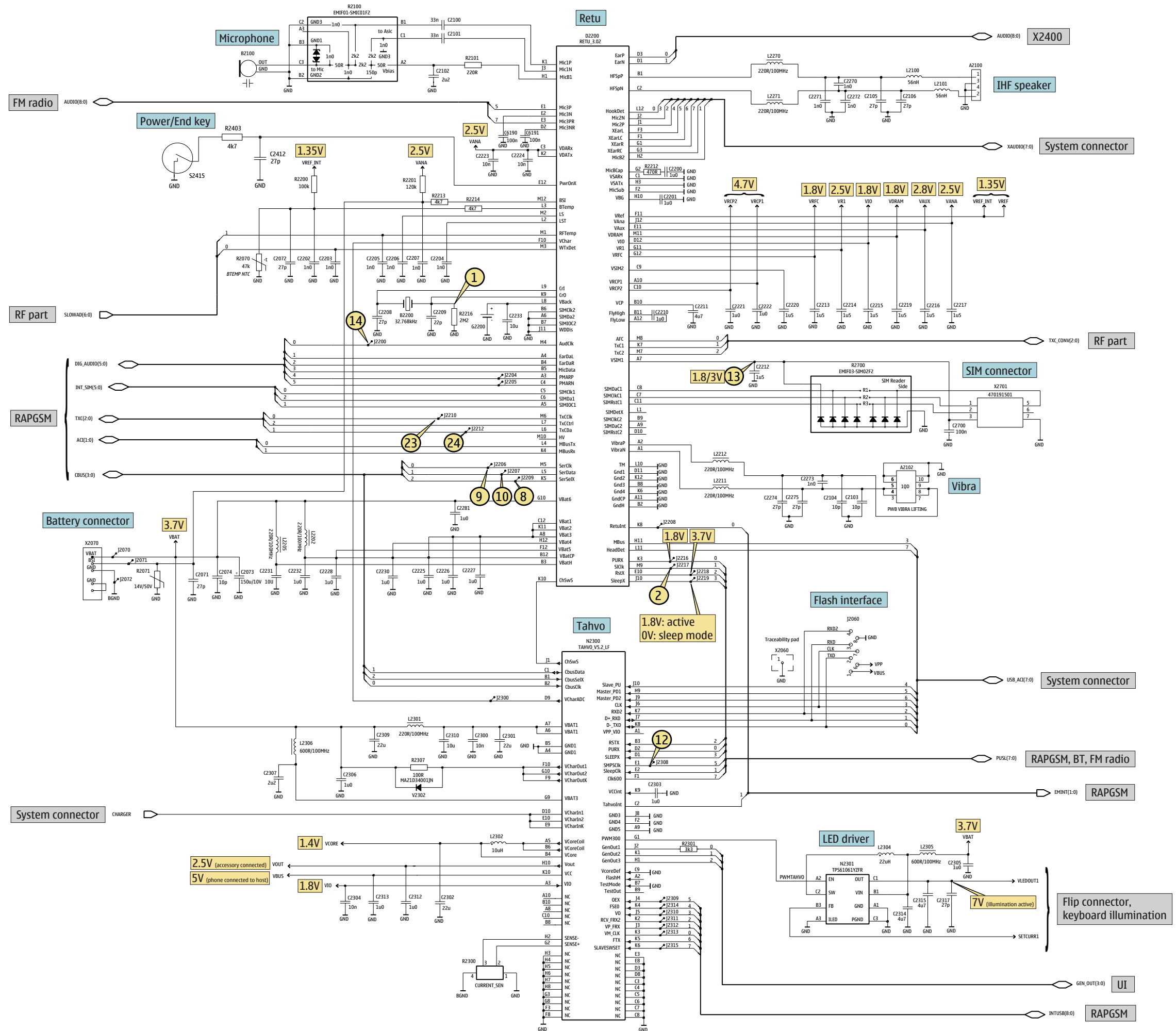

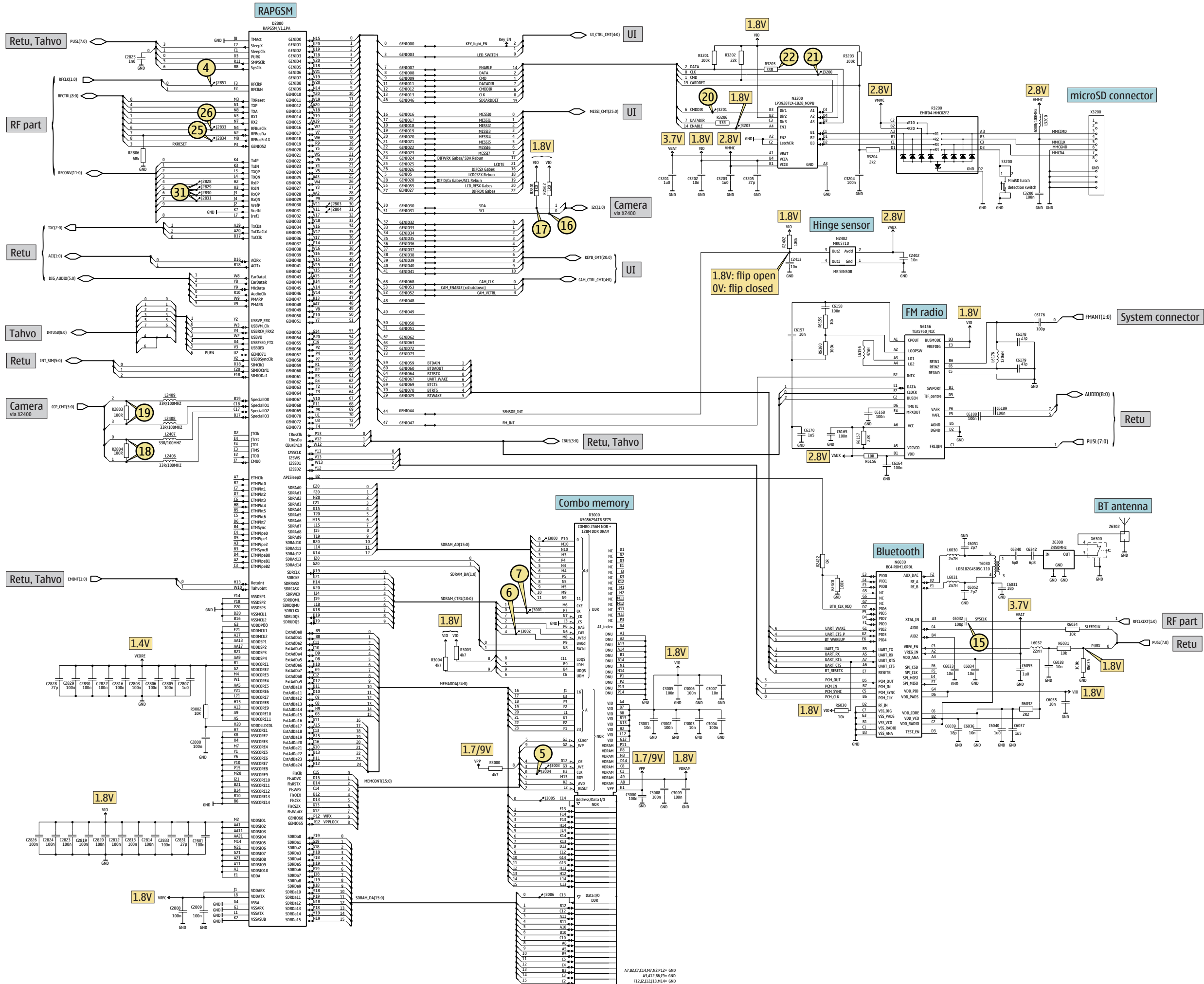

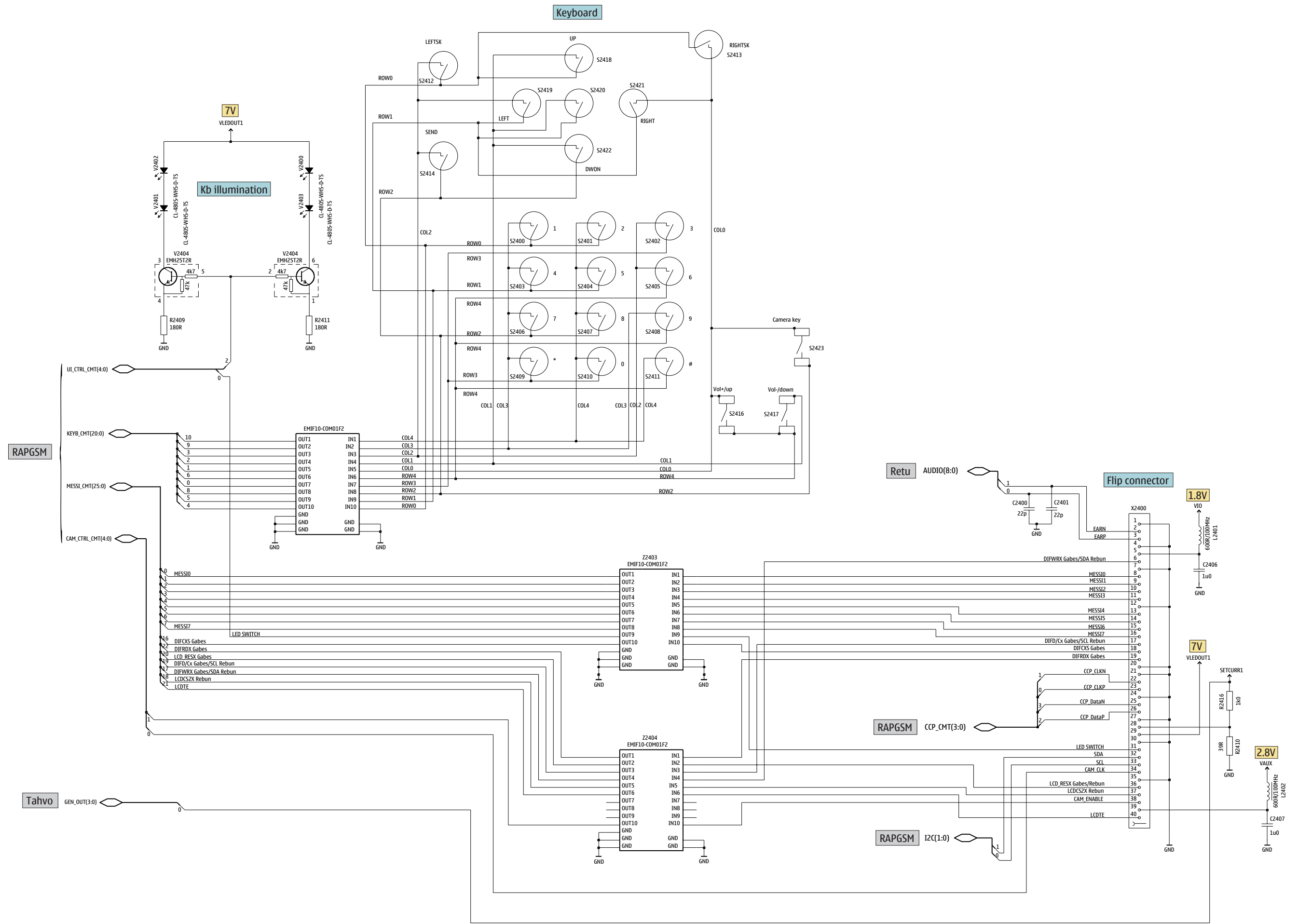

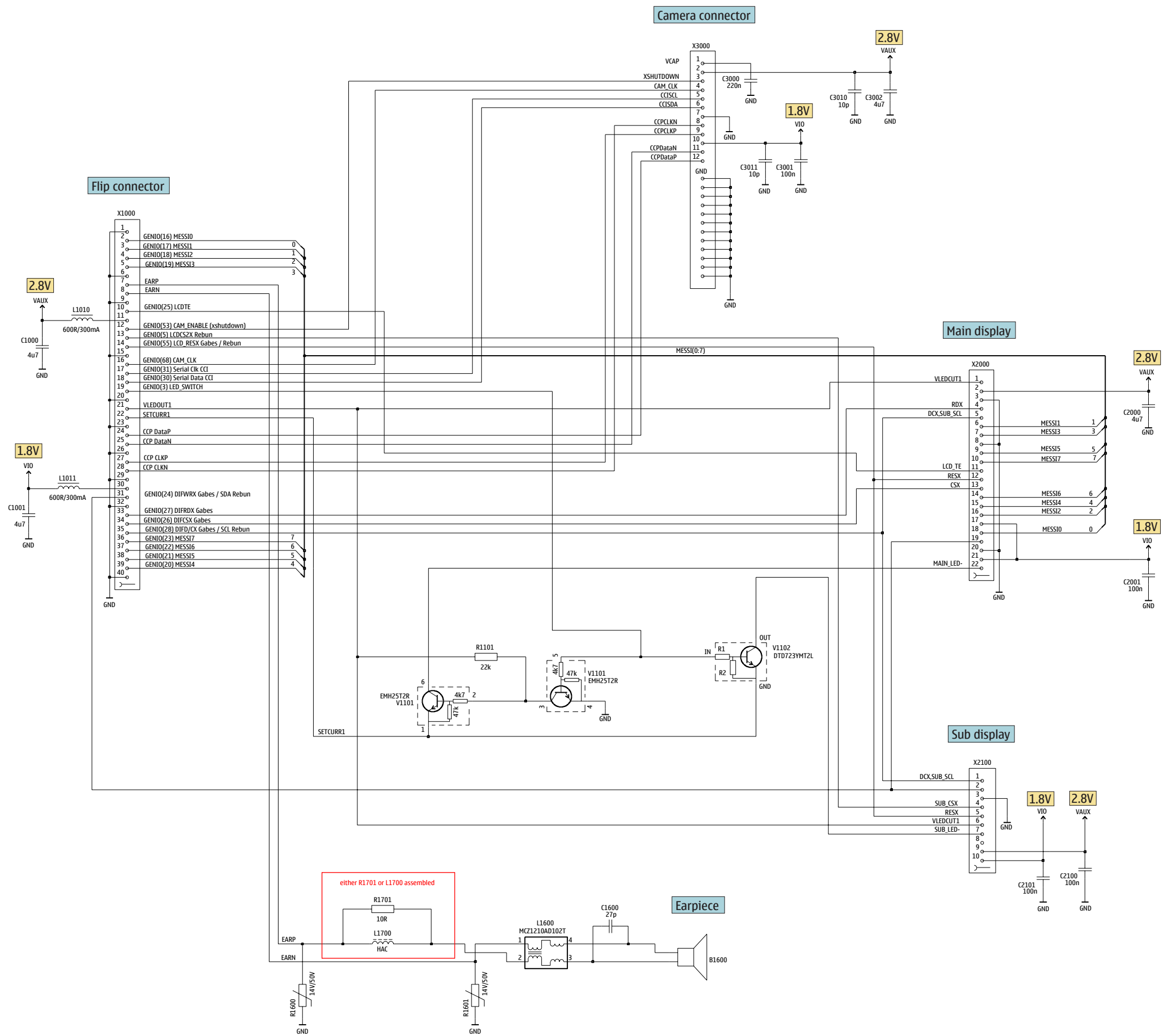

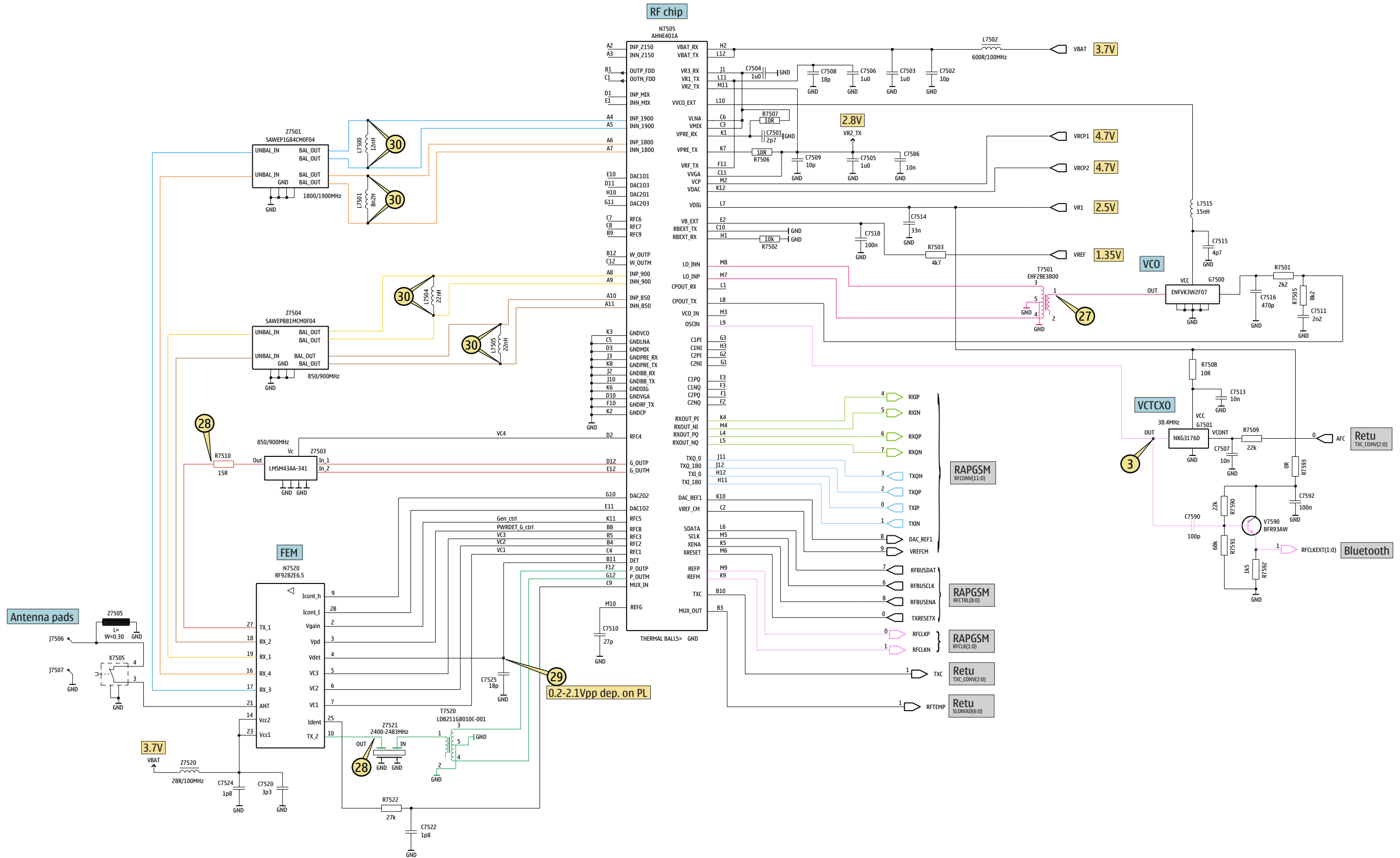

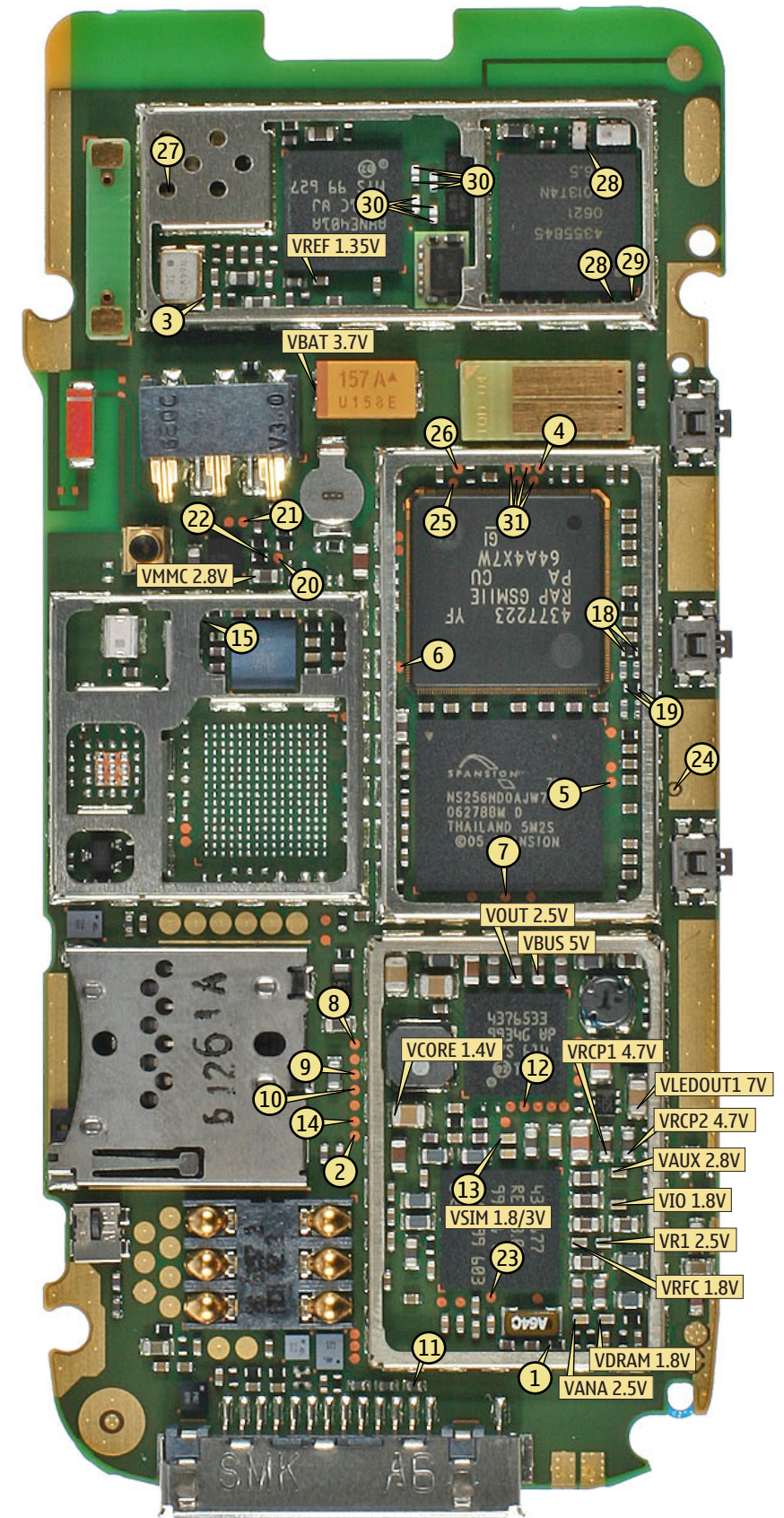
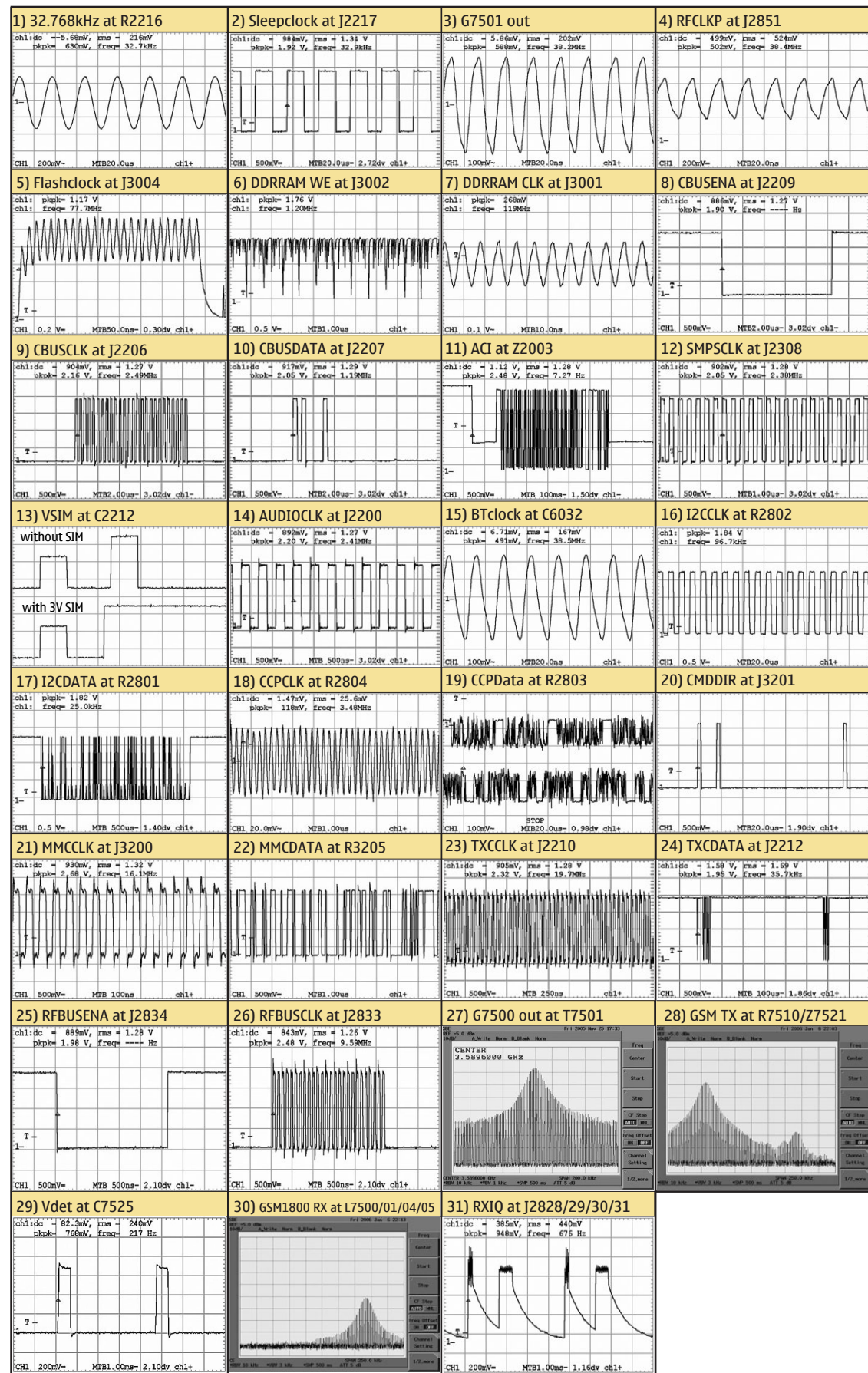

B	C2410	D3	C7525	D8	L2306	M4	R7510	D7	
B2100	Q1	C2411	D3	C7586	D5	L2401	B3	R7522	D7
B2200	P6	C2412	N6	C7590	K1	L2402	D2	R7590	K1
C	C2413	C7	C7592	J1	L2406	I8	R7591	K1	
C2000	N8	C2415	B3	D	L2407	I8	R7592	K2	
C2001	N8	C2416	D2	D2200	O6	L2408	I8	R7593	J1
C2002	R4	C2700	Q3	D2800	H6	L2409	I8	S	F8
C2003	R4	C2800	H8	D3000	J6	L3200	L2	S2416	F8
C2004	R4	C2801	F7	F	L6030	H3	S2417	H8	
C2005	R3	C2803	H8	F2000	P8	L6031	I3	S2423	K8
C2006	R3	C2805	F7	G	L6032	I4	S3200	O1	
C2007	Q2	C2806	F8	G2200	G4	L6156	R5	T	
C2008	Q3	C2807	I5	G7500	B3	L6176	R6	T6030	H2
C2009	Q3	C2808	G8	G7501	D2	L7500	C5	T7501	C2
C2010	Q3	C2809	G8	J	L7501	C5	T7520	B7	
C2011	R3	C2812	H8	J2000	P8	L7502	D4	V	
C2012	R3	C2813	F5	J2001	O8	L7503	D7	V2000	O8
C2013	R3	C2814	G8	J2002	P6	L7504	C5	V2302	L4
C2014	R3	C2815	F7	J2003	Q3	L7505	C5	V2400	O6
C2015	Q4	C2816	I5	J2004	Q3	L7515	C3	V2401	I6
C2016	P8	C2819	I5	J2005	R2	N	V2402	I3	
C2071	G3	C2820	F6	J2006	Q2	N2300	M6	V2403	O3
C2072	P2	C2822	F5	J2007	Q4	N2301	M8	V2404	N7
C2073	E5	C2823	I6	J2008	O4	N2402	D7	V7590	K1
C2074	F2	C2824	J5	J2009	P4	N3200	G3	X	
C2100	Q2	C2825	F7	J2060	P2	N6030	H3	X2000	R4
C2101	Q2	C2826	I7	J2070	E3	N6156	O5	X2002	R7
C2102	Q2	C2828	I7	J2071	E3	N7505	C4	X2060	B6
C2103	E8	C2829	G8	J2072	E4	N7520	C7	X2070	F3
C2104	E8	C2830	H5	J2200	N4	R	X2400	C3	
C2105	D2	C2831	I7	J2204	P5	R2000	Q4	X2701	P3
C2106	C2	C2833	I6	J2205	P6	R2001	Q4	X3200	M2
C2200	O5	C3000	K5	J2206	M4	R2002	Q3	X6300	G2
C2201	P7	C3001	J5	J2207	N4	R2003	Q3	X7505	C8
C2202	P8	C3002	K5	J2209	M4	R2004	Q2	Z	
C2203	P6	C3003	J8	J2210	P6	R2005	Q3	Z2000	Q5
C2204	P6	C3004	J8	J2212	J8	R2006	Q3	Z2001	Q4
C2205	P5	C3005	J8	J2216	N6	R2007	Q4	Z2003	Q5
C2206	P6	C3006	K8	J2217	N4	R2008	Q4	Z2400	D6
C2207	P7	C3007	K8	J2218	M4	R2009	Q4	Z2403	C4
C2208	Q6	C3008	J8	J2219	N4	R2070	P2	Z2404	C2
C2209	Q6	C3009	K8	J2300	N6	R2071	E3	Z6300	H2
C2210	N7	C3200	L2	J2308	N6	R2100	Q2	Z6302	F1
C2211	N7	C3201	G2	J2309	M7	R2101	P2	Z7501	C6
C2212	N6	C3202	G3	J2310	M7	R2102	D2	Z7503	D5
C2213	O7	C3203	H3	J2311	N7	R2103	C2	Z7504	C6
C2214	O7	C3204	L4	J2312	M7	R2200	P8	Z7520	B6
C2215	O7	C3205	G3	J2313	N7	R2201	P7	Z7521	B7
C2216	O7	C6031	I2	J2314	N7	R2212	O5		
C2217	P7	C6032	H2	J2315	M7	R2213	P7		
C2218	P6	C6033	H4	J2803	G5	R2214	P8		
C2219	P7	C6034	H3	J2804	G5	R2216	Q7		
C2220	N6	C6035	I4	J2828	F6	R2301	M8		
C2221	N8	C6036	H4	J2829	F6	R2307	L4		
C2222	N7	C6037	H4	J2830	F6	R2402	D7		
C2223	O5	C6038	H4	J2831	F6	R2403	N6		
C2224	P5	C6039	H3	J2833	F6	R2404	G1		
C2225	P7	C6040	I4	J2834	F6	R2409	N8		
C2226	O7	C6051	H3	J2851	F7	R2410	D4		
C2227	N6	C6052	I3	J3000	K6	R2411	N7		
C2228	O7	C6055	H2	J3001	K6	R2416	B3		
C2229	N6	C6056	H4	J3002	I5	R2420	H4		
C2230	P7	C6157	Q4	J3003	K6	R2422	G4		
C2231	N5	C6158	O5	J3004	J7	R2700	Q4		
C2232	O7	C6164	O5	J3005	J7	R2801	D3		
C2233	G4	C6165	R6	J3006	J7	R2802	D3		
C2270	O5	C6168	Q6	J3112	L4	R2803	I8		
C2271	O5	C6170	R5	J3113	L3	R2804	H8		
C2272	O5	C6176	R6	J3114	L3	R2806	F6		
C2273	N6	C6178	R6	J3115	L3	R3000	J5		
C2274	N6	C6179	Q6	J3116	L2	R3002	H8		
C2275	N5	C6188	O6	J3117	L2	R3003	I8		
C2281	O8	C6189	O6	J3118	L4	R3004	K7		
C2300	M5	C6190	P5	J3119	L4	R3200	L1		
C2301	L5	C6191	P5	J3200	G3	R3201	G4		
C2302	N5	C6340	I2	J3201	G3	R3202	G3		
C2303	L7	C6342	I2	J3203	G3	R3203	K5		
C2304	N6	C7501	B4	J7506	A8	R3204	L4		
C2305	L8	C7502	D4	J7507	C8	R3205	G3		
C2306	M4	C7503	D3	L	R3206	G4			
C2307	L6	C7504	B4	L2000	O8	R6030	H4		
C2309	L5	C7505	D3	L2001	O3	R6031	H4		
C2310	L6	C7506	D3	L2002	O3	R6032	I4		
C2312	L6	C7507	D3	L2003	R3	R6034	H3		
C2313	L7	C7508	D3	L2004	R3	R6035	H4		
C2314	M7	C7509	D3	L2100	D2	R6156	Q4		
C2315	N8	C7510	D4	L2101	C2	R6157	R6		
C2316	N8	C7511	C3	L2202	P8	R6159	R5		
C2317	O8	C7513	D3	L2205	P8	R6160	R4		
C2318	L8	C7514	D3	L2211	N5	R7501	C3		
C2400	N4	C7515	B3	L2212	N6	R7502	B4		
C2401	N4	C7516	C3	L2270	O5	R7503	D4		
C2402	D7	C7518	D4	L2271	O5	R7505	C3		
C2403	D2	C7520	B7	L2301	L5	R7506	D3		
C2404	D2	C7522	D6	L2302	M5	R7507	B4		
C2406	C3	C7523	B7	L2304	M7	R7508	D3		
C2407	D3	C7524	D6	L2305	L7	R7509	D3		

